

30x30x07mm (1.81"x1.81"x0.27")



Frame:Plastic(UL:94-0)  
 Impeller:Plastic(UL:94-0)  
 Lead wire:UL 1007AWG24  
 Red wire positive (+)  
 Black Wire negative (-)  
 Operation Temperature:-10°C-70°C  
 Motor Protection: Impedance Protected  
 Reverse Polarity Protected  
 Safety approval: UL TUV CE

Specifications(Nominal)

S=Sleeve bearing B=One ball bearing D=Two ball bearing

Model No.	Bearing System Type	Rated Voltage (VDC)	Speed Type	Rated Current (A)	Rated Speed (RPM)	Air Flow (CFM)	Aire Pressure (mmAg)	Noise Level (dBA)	Weight (g)
HT□D03007	S/B	5	H	0.18	11000	3.61	4.21	32.0	6
			M	0.12	9000	3.08	3.44	28.0	
			L	0.09	7500	2.55	2.75	22.0	
		12	H	0.10	11000	3.61	4.21	32.0	
			M	0.08	9000	3.08	3.44	28.0	
			L	0.06	7500	2.55	2.75	22.0	

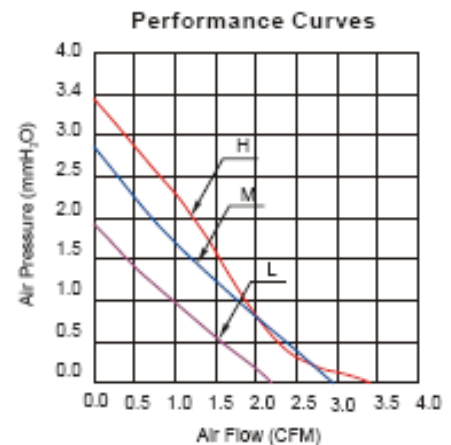
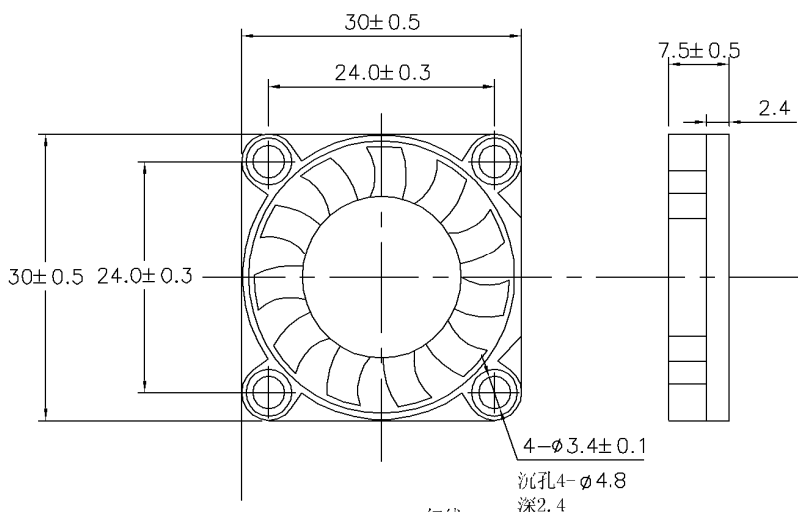

\* All reading are typical values at rated voltage.  
 \* Specifications subjected to change without notice